

## ETATRACK active 1000-30 Single-axis Tracking System for PV Modules

### Characteristics

- total module surface up to c. 10.5 m<sup>2</sup>
- no failure-prone light sensor
- no unnecessary tracking movements
- low power consumption (c. 1 kWh/year)
- statics according to German and European standards
- high reliability and life-expectancy
- maintenance-free
- cost-efficient tracking system



### Application

- single-axis tracking system for PV modules\*
- additional energy yield of up to 40 % compared to fixed installations

### Design

#### Tracking Unit

- single-axis tracking system
- angle of second axis 30°, fixed (other angles on request)
- elevation East-West: 90°
- module surface up to c. 10.5 m<sup>2</sup>  
max. dimensions of mounted frames (supportive area, installation area PV modules): width: upper row: 3.3 m, middle row: 2.5 m, lower row: 1.5 m, height over all rows: 3.7 m
- frame and supports: steel, hot-dip Zn-coated
- screw set: steel, Zn-coated
- module clamps made of stainless steel for mounting the PV modules using the holes in the module frame, incl. M6 stainless steel screw kits
- suitable for high wind speeds: statics according to German and European standards
- low energy consumption c. 1 kWh/year
- maintenance-free

\* for framed PV modules according to IEC 61215, UL 1703

\*\* for safe operation in specific system designs, an additional small module might be necessary, cf. installation manual

\*\*\* for safe operation, cf. installation manual

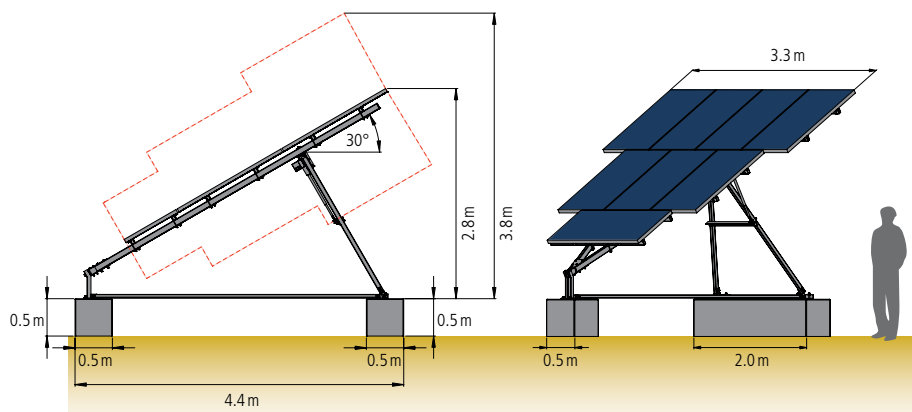

Example: system dimensions with 8 PV modules, c. 1.6 m x 0.8 m

#### Control

- electronics incl. battery in plastic housing
- supply voltage: 12V DC (nominal voltage) up to 50V<sub>oc</sub> (open-circuit voltage), by one of the tracked modules\*\*
- stepwise tracking, depending on the daily sunshine duration (length of day)
- South position in darkness
- synchronisation of multiple units possible
- standby mode in periods of low irradiation\*\*\*

#### Drive

- DC linear drive
- maintenance-free

#### Foundation

- concrete foundation with steel reinforcement, front foundation min. 0.1 m<sup>3</sup>, rear foundation min. 0.5 m<sup>3</sup>

#### Storage and Operating Conditions

- ambient temperature range: -25 °C to +50 °C
- daily average ambient humidity: max. 80 %
- air salinity: max. 2 µg/m<sup>3</sup>, or distance from coast: min. 1 km
- altitude: -400 m to +3,000 m MSL
- for detailed description of ambient conditions for safe operation, cf. installation manual
- designs for other conditions on request

#### Included in Delivery

- kit tracking unit
- module clamps (cf. design): 48 sets per tracking unit for 12 PV modules in upright position and 4 sets for one PV module for lengthwise installation
- control
- drive
- installation manual